

STEP PULLEYS: MAS

DID YOU KNOW THAT...

- Commonly used with drill presses & wood lathes
- All bores come with 2 set screws
- Designed for A, 4L & 3L V-Belts
- Models of 3 to 5 steps
- From 2"-6" diameter



HOW TO ORDER

EXAMPLE: **MAS62X1/2**

M

AS

62

X1/2

M: MASKA LIGHT DUTY FAMILY

AS: STEP PULLEY SERIE

62: OUTSIDE DIAMETERS

THE FIRST DIGIT REPRESENTS THE LARGEST OUTSIDE DIAMETER (6")

THE SECOND DIGIT REPRESENTS THE SMALLEST OUTSIDE DIAMETER (2")

X1/2: BORE SIZE (1/2")

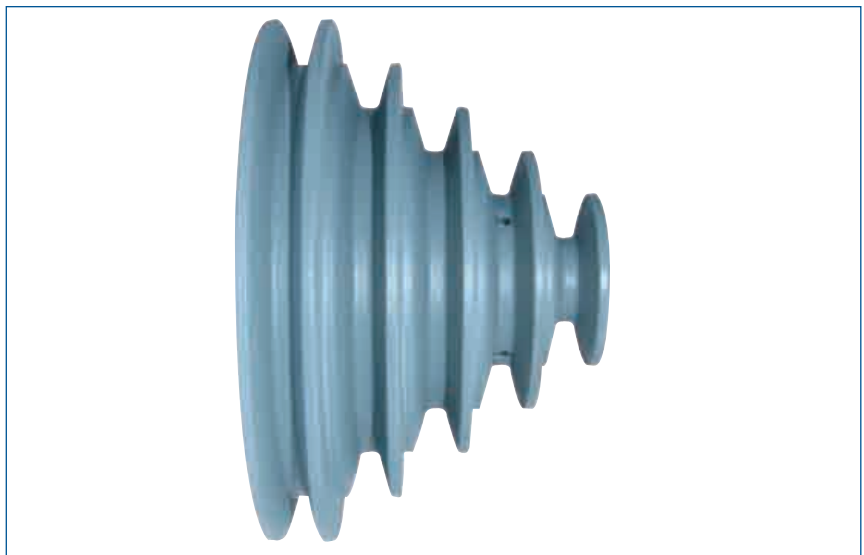

FIXED BORE, STOCK SIZES FOR 3L-4L (A) V-BELTS

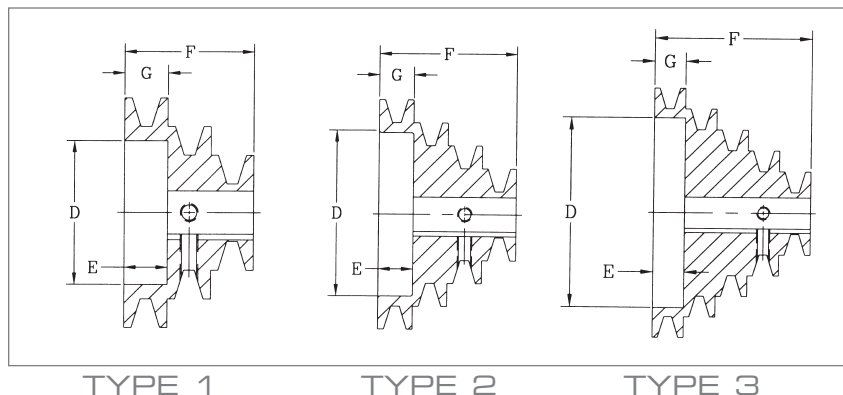

DIMENSIONS

Part No	List Price \$	Type	Outside Diameters	Stock Bores	Dimensions (inches)				Wt
					D	G	F	E	
MAS62	91.80	3	6" 5" 4" 3" 2"	1/2-5/8-3/4-7/8	4 9/16	3/4	3 3/4	3/4	8.0
MAS63	78.80	2	6" 5" 4" 3"	1/2-5/8-3/4-7/8-1-1 1/8	4 9/16	3/4	3	3/4	7.5
MAS64	65.30	1	6" 5" 4"	1/2-5/8-3/4-7/8-1-1 1/8	4 9/16	3/4	2 1/4	3/4	6.5
MAS52	67.30	2	5" 4" 3" 2"	1/2-5/8-3/4-7/8	3 9/16	3/4	3	3/4	4.5
MAS53	56.60	1	5" 4" 3"	1/2-5/8-3/4-7/8-1-1 1/8	3 9/16	3/4	2 1/4	3/4	4.2
MAS42	46.10	1	4" 3" 2"	1/2-5/8-3/4-7/8	2 1/2	3/4	2 1/4	3/4	2.3

D.D. for "A"(4L) belts = O.D. - .25"
 D.D. for 3L belts = O.D. - .59"

P.D. for "A"(4L) belts = O.D.
 P.D. for 3L belts = O.D. - .34"

Bore Range	Keyseat
1/2"	None
5/8" - 7/8"	3/16" X 3/32"
15/16" - 1-1/4"	1/4" X 1/8"

SHEAVES