

MASKAFLEX

ELASTOMERIC TIRE TYPE



Maska EZ-Shelf On-Line
Ordering - see page 162

Most suitable coupling for applications with shock loads, angular misalignment up to 4° and end float up to ¼".

Fits with our QD bushing for easier installation and dismounting and has greater versatility than the fixed bore style without damaging the shaft.

DID YOU KNOW THAT...

- Superior European designed and manufactured "X-Tork" tire
- Bonded and thermally stabilized rubber with double-woven textile cords & cord reinforced bead for greater torque capacity
- Ridged extremity & inner sidewalls designed for enhance grip of the flanges

IMPORTANT REMINDER



- **Maska Flex couplings are balanced to meet general industrial applications. Applications with a speed superior to 5,000 fts./min. may require more accurate balancing.**
- **Shaft ends can project beyond the bushing. If this occurs, allow space between shaft ends for endfloat & misalignment.**
- **The standard tire element in natural rubber is designed for temperatures between -42°C and +82°C.**

MASKAFLEX ELASTOMERIC TIRE TYPE



HOW TO ORDER

COMPLETE COUPLING

EXAMPLE: **MX 120**

MX 120

MX 120: COMPLETE MASKAFLEX PART NUMBER

FLANGE

EXAMPLE: **MXF 120**

MXF 120

MXF 120: MASKAFLEX FLANGE PART NUMBER

ELEMENT MATERIAL

EXAMPLE: **P120**

P120

P120: MASKAFLEX ELEMENT PART NUMBER
(TIRE)

A complete Maskaflex coupling corresponds to (2) flanges and (1) element. Specify the bore size required to order the appropriate QD bushing with it.





CROSS REFERENCES

MASKA-FLEX Maska	HI-FLEX Maurey	*PARA-FLEX Dodge	MARTIN-FLEX Martin
MX50	50JA	PX50	F5 JA
MX60	60SH	PX60	F6 JA
MX70	70SH	PX70	F7 SH
MX80	80SDS	PX80	F8 SDS
MX90	90SK	PX90	F9 SK
MX100	100SF	PX100	F10 SF
MX110	110SF	PX110	F11 SF
MX120	120E	PX120	F12 E
MX140	140E	PX140	N/A
MX160	N/A	PX160	N/A
MX200	N/A	PX200	N/A

* Paraflex Couplings are designed for use with taper-lock bushings.

WRENCH TORQUE TO TIGHTEN SCREWS

Coupling No.	CAPSCREW	TORQUE
MX50	1/4-20UNC x 1	96 in-lbs
MX60	1/4-20UNC x 1-1/4	96 in-lbs
MX70	5/16-18UNC x 1-1/2	205 in-lbs
MX80	5/16-18UNC x 1-1/2	205 in-lbs
MX90	3/8-16 x 1-3/4	360 in-lbs
MX100	3/8-16 x 1-3/4	360 in-lbs
MX110	3/8-16 x 2	360 in-lbs
MX120	1/2-13UNC x 2-1/4	900 in-lbs
MX140	1/2-13UNC x 2-1/2	900 in-lbs
MX160	5/8-11UNC x 3 Grade 8	1800 in-lbs
MX200	5/8-11UNC x 4 Grade 8	1800 in-lbs

Flexible elastomeric element

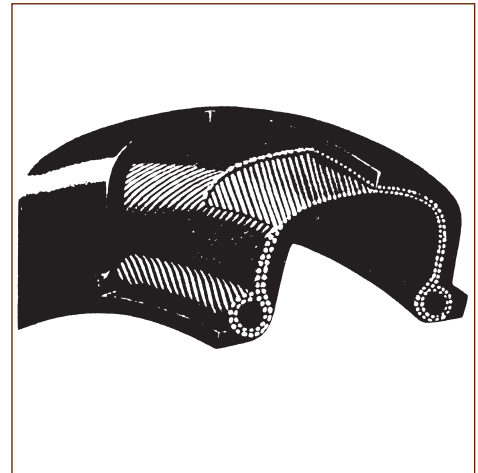

Easy to Assemble

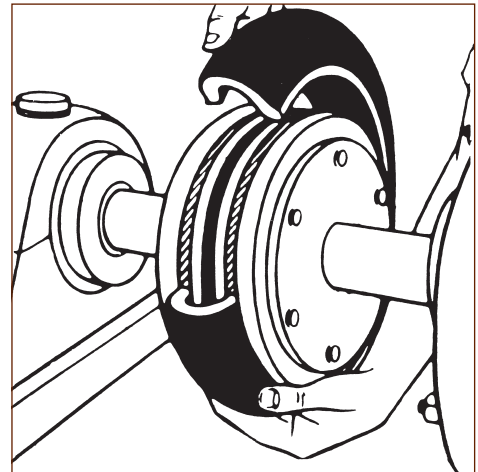

DIMENSIONS

Complete Coupling Part No	List price w/o Bushing			Bush. Size	Max. Bore	Type	Dimensions (inches)						Weight (lbs)			
	Complete Coupling	Tire only	Flange only				A	B	C	D	E	F	G	Complete	Flange	Tire
MX50**	114.00	40.00	37.00	JA	1 1/4	1	5 1/4	3 7/8	3 23/32	3 17/32	7/8	*	1 17/32	4.7	2.1	.5
MX60	151.00	47.00	52.00	SH	1 5/8	1	6 1/2	4 23/32	4 1/2	4 9/32	1 9/32	*	1 25/32	8.0	3.5	1.0
MX70	201.00	65.00	68.00	SDS	1 15/16	1	7 3/8	4 17/32	4 5/16	4 1/8	1 1/2	*	1 1/2	10.7	4.7	1.3
MX80	265.00	87.00	89.00	SK	2 1/2	1	8 3/8	5 13/16	5 17/32	5 1/4	1 1/2	*	1 1/2	15.5	6.9	1.7
MX90	335.00	93.00	121.00	SK	2 1/2	1	9 1/4	5 7/8	5 9/16	5 5/16	1 17/32	*	1 9/16	22.0	10.0	2.0
MX100	411.00	101.00	155.00	SF	2 3/4	1	10	6 1/8	5 25/32	5 15/32	1 23/32	*	1 15/32	32.0	15.0	2.0
MX110	457.00	115.00	171.00	SF	2 3/4	1	11	5 7/8	5 1/2	5 3/16	1 9/16	*	1 3/16	46.0	21.5	3.0
MX120	529.00	129.00	200.00	E	3 7/16	1	12 3/8	7 1/4	6 7/8	6 1/2	1 3/4	*	1 1/4	59.8	28.0	3.8
MX140	918.00	210.00	354.00	F	3 15/16	2	14 1/8	9 1/2	9 1/16	8 5/8	2 1/16	*	1 3/8	132.5	64.0	4.5
MX160	1352.00	252.00	550.00	J	4	2	16 5/8	11 1/2	10 7/8	10 3/8	2 11/16	*	1 3/8	208.7	100.0	8.7
MX200	2043.00	463.00	790.00	J	4	2	20	11 3/4	11 5/16	10 13/16	3 5/16	*	1 13/16	366.0	174.0	18.0

→ Maximum bore with keyseat

* Shaft ends although normally "G" distance apart can project beyond the bushings and be closer together. If this occurs, allow space between shaft ends for endfloat and misalignment.

** The MX50 coupling can only be outside-outside mount.

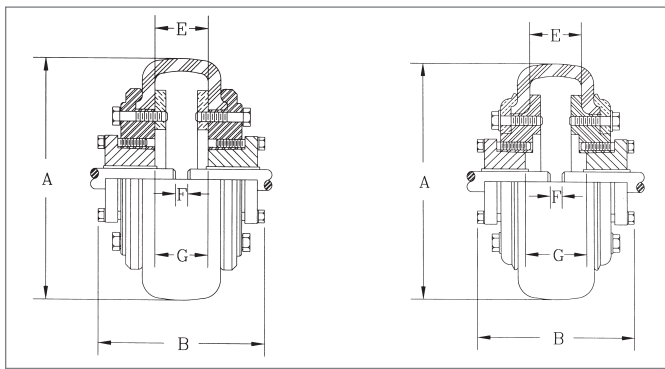

MX 50 TO
MX 120

MX 140 TO
MX 200

TYPE 1

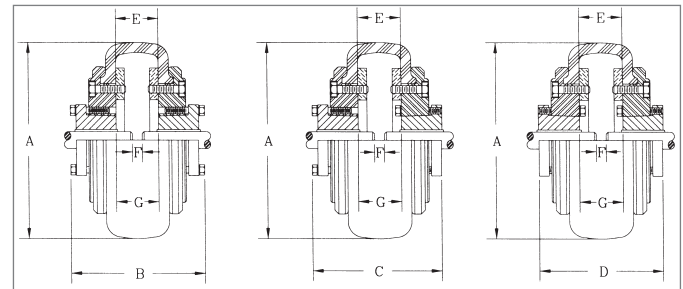

OUTSIDE-
OUTSIDE
MOUNT

OUTSIDE-
INSIDE
MOUNT

INSIDE-
INSIDE
MOUNT

TYPE 2

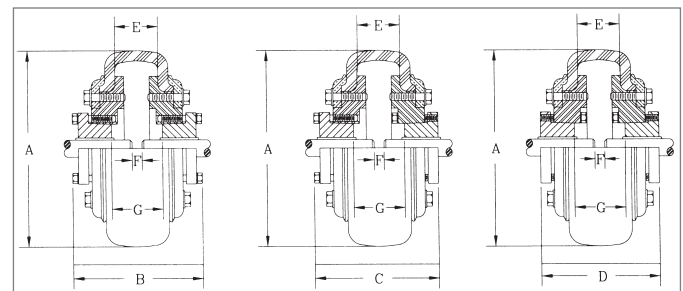

OUTSIDE-
OUTSIDE
MOUNT

OUTSIDE-
INSIDE
MOUNT

INSIDE-
INSIDE
MOUNT



COUPLING RATINGS & MISALIGNMENT

Coupling No.	Bush. Size	Max. Bore	Max RPM	HP per 100 RPM Service factors					Torque* @ 1.0 S.F. (LB in)	Average static torsional stiffness coefficient (H)		Approx. WR2 (LB-FT ²)	Max. parallel misalignment	Max. axial misalignment
				1.0	1.5	2.0	2.5	3.0		LB-IN/DEG.	LB-IN/RAD.			
MX50	JA	1 1/4	4500	1.43	.95	.72	.57	.48	900	224	12,850	.08	3/64	1/16
MX60	SH	1 5/8	4000	2.86	1.91	1.43	1.14	.95	1,800	414	23,700	.24	1/16	5/64
MX70	SDS	1 15/16	3600	3.49	2.33	1.75	1.40	1.16	2,200	544	31,200	.45	5/64	3/32
MX80	SK	2 1/2	3100	5.71	3.81	2.86	2.28	1.90	3,600	876	50,200	.88	5/64	7/64
MX90	SK	2 1/2	2800	6.90	4.60	3.45	2.76	2.30	4,350	1,088	62,400	1.60	3/32	1/8
MX100	SF	2 3/4	2600	8.33	5.55	4.17	3.33	2.78	5,250	1,530	87,700	2.90	7/64	1/8
MX110	SF	2 3/4	2300	12.30	8.20	6.15	4.92	4.10	7,750	2,420	138,700	4.30	7/64	9/64
MX120	E	3 7/16	2100	19.90	13.27	9.95	7.96	6.63	12,540	4,014	217,000	6.70	1/8	5/32
MX140	F	3 15/16	1840	43.78	29.19	21.89	17.51	14.59	27,590	8,296	476,000	19.50	9/64	3/16
MX160	J	4	1560	59.98	39.99	29.99	23.99	19.99	37,800	12,000	688,000	34.60	11/64	13/64
MX200	J	4	1300	130.90	87.27	65.45	52.36	43.63	82,500	29,000	1,662,000	103.00	13/64	17/64

* To obtain the maximal torque, multiply by 2.5 the nominal torque. (X-Tork tire)

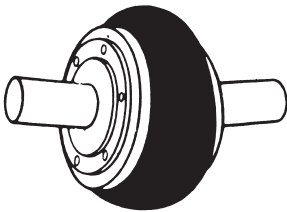

Max. angular misalignment: 4°

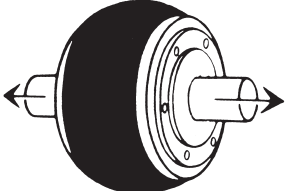

Max. axial misalignment: see Table above

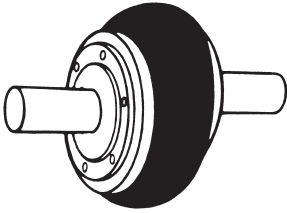

Max. parallel misalignment: see Table above

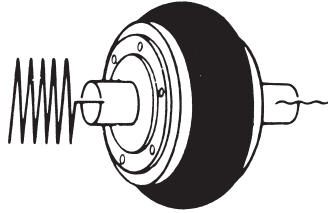

Dampens vibrations



ORDER ENTRY PART # ON EZ-SHELF WEB SITE

Note: A complete Maskaflex coupling corresponds to two (2) flanges and one (1) element and must be ordered separately.

Compl. Coup. #	Flange Part #	Tire Part #
;MX50	;MXF 50	;P50
;MX60	;MXF 60	;P60
;MX70	;MXF 70	;P70
;MX80	;MXF 80	;P80
;MX90	;MXF 90	;P90

Compl. Coup. #	Flange Part #	Tire Part #
;MX100	;MXF 100	;P100
;MX 110	;MXF 110	;P110
;MX 120	;MXF 120	;P120
;MX 140	;MXF 140	;P140
;MX 160	;MXF 160	;P160
;MX 200	;MXF 200	;P200

160

COUPLING SELECTION - SERVICE FACTORS



860 RPM MOTORS						
HP	COMPUTER HP / 100 RPM FOR 860 RPM MOTOR	SERVICE FACTOR				
		1.0	1.5	2.0	2.5	3.0
1/2	.058	*50JA	*50JA	*50JA	*50JA	*50JA
3/4	.087	*50JA	*50JA	*50JA	*50JA	*50JA
1	.116	*50JA	*50JA	*50JA	*50JA	*50JA
1 1/2	.174	*50JA	*50JA	*50JA	*50JA	*50JA
2	.232	*50JA	*50JA	*50JA	*50JA	*50JA
3	.349	*50JA	*50JA	*50JA	*50JA	*50JA
5	.581	*50JA	*50JA	*50JA	60SH	60SH
7 1/2	.872	*50JA	*50JA	60SH	60SH	60SH
10	1.16	*50JA	60SH	60SH	70SDS	70SDS
15	1.74	60SH	60SH	70SDS	80SK	80SK
20	2.33	60SH	70SDS	80SK	90SK	100SF
25	2.91	70SDS	80SK	90SK	100SF	110SF
30	3.49	70SDS	80SK	100SF	110SF	110SF
40	4.65	80SK	100SF	110SF	110SF	120E
50	5.81	90SK	110SF	110SF	120E	120E
60	6.98	100SF	110SF	120E	120E	140F
75	8.72	110SF	120E	120E	140F	140F
100	11.63	110SF	120E	140F	140F	140F

1160 RPM MOTORS						
HP	COMPUTER HP / 100 RPM FOR 1160 RPM MOTOR	SERVICE FACTOR				
		1.0	1.5	2.0	2.5	3.0
3/4	.065	*50JA	*50JA	*50JA	*50JA	*50JA
1	.086	*50JA	*50JA	*50JA	*50JA	*50JA
1 1/2	.129	*50JA	*50JA	*50JA	*50JA	*50JA
2	.172	*50JA	*50JA	*50JA	*50JA	*50JA
3	.259	*50JA	*50JA	*50JA	*50JA	*50JA
5	.431	*50JA	*50JA	*60JA	*50JA	*50JA
7 1/2	.647	*50JA	*50JA	*50JA	60SH	60SH
10	.862	*50JA	*50JA	60SH	60SH	60SH
15	1.29	*50JA	60SH	60SH	70SDS	80SK
20	1.72	60SH	60SH	70SDS	80SK	80SK
25	2.16	60SH	70SDS	80SK	80SK	90SK
30	2.59	60SH	80SK	80SK	90SK	100SF
40	3.45	70SDS	80SK	90SK	110SF	110SF
50	4.31	80SK	90SK	110SF	110SF	120E
60	5.17	80SK	100SF	110SF	120E	120E
75	6.47	90SK	110SF	120E	120E	120E
100	8.62	110SF	120E	120E	140F	140F
125	10.78	110SF	120E	140F	140F	140F

Bushing sizes shown above may not always have shaft size capacity capabilities.
* 50JA MASKAFLEX couplings are outside-outside mount only.



1750 RPM MOTORS						
HP	COMPUTER HP / 100 RPM FOR 1750 RPM MOTOR	SERVICE FACTOR				
		1.0	1.5	2.0	2.5	3.0
1	.057	*50JA	*50JA	*50JA	*50JA	*50JA
1 1/2	.086	*50JA	*50JA	*50JA	*50JA	*50JA
2	.114	*50JA	*50JA	*50JA	*50JA	*50JA
3	.171	*50JA	*50JA	*50JA	*50JA	*50JA
5	.286	*50JA	*50JA	*50JA	*50JA	*50JA
7 1/2	.429	*50JA	*50JA	*50JA	*50JA	*50JA
10	.571	*50JA	*50JA	*50JA	*50JA	*50JA
15	.857	*50JA	*50JA	60SH	60SH	60SH
20	1.14	*50JA	60SH	60SH	60SH	70SDS
25	1.43	*50JA	60SH	60SH	80SK	80SK
30	1.71	60SH	60SH	70SDS	80SK	80SK
40	2.28	60SH	70SDS	80SK	80SK	90SK
50	2.86	60SH	80SK	80SK	100SF	110SF
60	3.43	70SDS	80SK	90SK	110SF	110SF
75	4.28	80SK	90SK	110SF	110SF	120E
100	5.71	80SK	110SF	110SF	120E	120E
125	7.14	100SF	110SF	120E	120E	140F
150	8.57	110SF	120E	120E	140F	140F
200	11.43	110SF	120E	140F	140F	140F

3500 RPM MOTORS						
HP	COMPUTER HP / 100 RPM FOR 3500 RPM MOTOR	SERVICE FACTOR				
		1.0	1.5	2.0	2.5	3.0
1 1/2	.044	*50JA	*50JA	*50JA	*50JA	*50JA
2	.057	*50JA	*50JA	*50JA	*50JA	*50JA
3	.086	*50JA	*50JA	*50JA	*50JA	*50JA
5	.143	*50JA	*50JA	*50JA	*50JA	*50JA
7 1/2	.214	*50JA	*50JA	*50JA	*50JA	*50JA
10	.286	*50JA	*50JA	*50JA	*50JA	*50JA
15	.429	*50JA	*50JA	*50JA	*50JA	*50JA
20	.571	*50JA	*50JA	*50JA	*50JA	60SH
25	.714	*50JA	*50JA	*50JA	60SH	60SH
30	.857	*50JA	*50JA	60SH	60SH	60SH
40	1.14	*50JA	60SH	60SH	70SDS	70SDS
50	1.428	*50JA	60SH	60SH	--	--
60	1.71	60SH	60SH	70SDS	--	--
75	2.14	60SH	70SDS	--	--	--
100	2.86	60SH	--	--	--	--
125		--	--	--	--	--
150		--	--	--	--	--
200		--	--	--	--	--
250		--	--	--	--	--

COUPLINGS

Bushing sizes shown above may not always have shaft size capacity capabilities.
 * 50JA MASKAFLEX couplings are outside-outside mount only.