

## VP SERIES



### DID YOU KNOW THAT...

- Maska 1VP and 2VP Series are finished bore variable speed sheaves made of cast iron and designed for heavier duty service up to 25HP
- Available in single and double grooves, they offer a pitch range from 1.9" to 6.7" (A belt) and 2.4" to 7.0" (B belt)
- Type 2 model has positive locked-on settings

### HOW TO ORDER

EXAMPLE: **1VP71X3/4**

**1**

**VP71**

**X3/4**

**1:** NUMBER OF GROOVES

**VP71:** ADJUSTABLE PITCH SHEAVE SIZE  
Last 2 digits represent the approximate outside diameter (7.1")

**X3/4:** BORE SIZE (3/4")

**Bore size:** Inch bore sizes are designated with the whole inch followed by the fraction. For example, a 1.5" diameter bore would be 1-1/2.



### Pulley Adjustment

Modify the sheave pitch diameter by rotating the adjustable flange on the threaded hub of the pulley. Once the required diameter is obtained, tighten the adjusting screw(s) on one of the two flat surfaces.

To obtain the same pitch diameter in both grooves of the VP series, tighten both movable flanges against the central flange, make trace marks on both flanges, then rotate both flanges the same number of turns.

## 1VP & 2VP SERIES

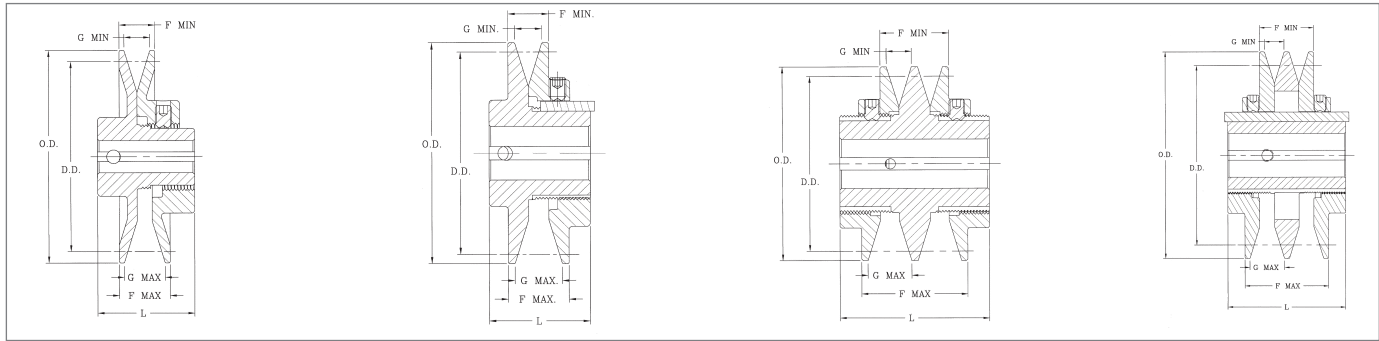

TYPE 1  
(without key)

TYPE 2

TYPE 3  
(without key)

TYPE 4

SHEAVES

### DIMENSIONS

Part No.	List Price \$	Type	O.D.	L	F		G		Available Stock Bores	Weight (lbs)
					Max.	Min.	Max.	Min.		
1VP25	36.96	1	2.50	1 1/2	13/16	9/16	5/8	3/8	*1/2	7
1VP30	37.52	1	2.87	1 21/32	13/16	9/16	5/8	3/8	*1/2 - 5/8 - 3/4	1.1
1VP34	47.20	1	3.15	1 7/8	1	11/16	13/16	1/2	*1/2 - 5/8 - 3/4 - 7/8	1.4
1VP40	47.80	1	3.75	1 7/8	1 1/16	11/16	7/8	1/2	*1/2 - 5/8 - 3/4 - 7/8	1.9
1VP44	51.60	1	4.15	1 7/8	1 1/16	11/16	7/8	1/2	*1/2 - 5/8 - 3/4	2.4
1VP44	71.60	2	4.15	1 7/8	1 1/8	3/4	7/8	1/2	7/8 - 1 - 1 1/8	2.9
1VP50	60.80	1	4.75	2	1 1/16	11/16	7/8	1/2	*1/2 - 5/8 - 3/4	2.9
1VP50	87.00	2	4.75	1 7/8	1 1/8	3/4	7/8	1/2	7/8 - 1 - 1 1/8	3.6
1VP56	90.80	1	5.35	1 7/8	1 1/16	11/16	7/8	1/2	*1/2 - 5/8 - 3/4	3.8
1VP56	117.20	2	5.35	1 7/8	1 1/8	3/4	7/8	1/2	7/8 - 1 - 1 1/8	4.4
1VP60	142.00	2	6.00	1 21/32	1 1/4	7/8	1 1/32	21/32	3/4 - 7/8 - 1 1/8 - 1 3/8	6.5
1VP62	143.30	2	5.95	1 29/32	1 1/8	3/4	7/8	1/2	5/8 - 3/4 - 7/8 - 1 - 1 1/8 - 1 1/4 - 1 3/8	6.1
1VP65	148.60	2	6.50	1 21/32	1 1/4	7/8	1 1/32	21/32	3/4 - 7/8 - 1 1/8 - 1 3/8	6.8
1VP68	149.20	2	6.55	1 29/32	1 1/8	3/4	7/8	1/2	5/8 - 3/4 - 7/8 - 1 - 1 1/8 - 1 1/4 - 1 3/8	7.3
1VP71	158.40	2	7.10	1 21/32	1 1/4	7/8	1 1/32	21/32	3/4 - 7/8 - 1 1/8 - 1 3/8	8.2
1VP75	211.40	2	7.50	1 21/32	1 1/4	7/8	1 1/32	21/32	3/4 - 7/8 - 1 1/8 - 1 3/8	9.2
2VP36	113.60	3	3.35	3	2	1 3/8	13/16	1/2	*1/2 - 5/8 - 3/4 - 7/8 - 1	3.4
2VP42	130.20	3	3.95	3	2 1/8	1 3/8	7/8	1/2	5/8 - 3/4 - 7/8 - 1 - 1 1/8	4.4
2VP50	150.00	4	4.75	3	2 1/8	1 3/8	7/8	1/2	5/8 - 3/4 - 7/8 - 1 - 1 1/8	6.3
2VP56	176.60	4	5.35	3	2 1/8	1 3/8	7/8	1/2	5/8 - 3/4 - 7/8 - 1 - 1 1/8	7.8
2VP60	225.60	4	6.00	3 1/4	2 3/8	1 5/8	1 1/32	21/32	3/4 - 7/8 - 1 1/8 - 1 3/8	10.6
2VP62	225.80	4	5.95	3	2 1/8	1 3/8	7/8	1/2	3/4 - 7/8 - 1 - 1 1/8 - 1 1/4 - 1 3/8	10.0
2VP65	242.00	4	6.50	3 1/4	2 3/8	1 5/8	1 1/32	21/32	3/4 - 7/8 - 1 1/8 - 1 3/8	12.3
2VP68	249.80	4	6.55	3	2 1/8	1 3/8	7/8	1/2	7/8 - 1 - 1 1/8 - 1 1/4 - 1 3/8	11.7
2VP71	256.00	4	7.10	3 1/4	2 3/8	1 5/8	1 1/32	21/32	3/4 - 7/8 - 1 1/8 - 1 3/8	14.6
2VP75	379.20	4	7.50	3 1/4	2 3/8	1 5/8	1 1/32	21/32	3/4 - 7/8 - 1 1/8 - 1 3/8	16.5

\* Supplied without keyway thru the bore