

## 4-FLEX: ELASTOMERIC GEAR TYPE COUPLINGS



### DID YOU KNOW THAT...

- Maska 4-Flex part # are based on industry recognized nomenclature
- 4-way flexing action
- All types & sizes in cast iron
- Precise concentric product to avoid run-out and unbalance
- No lubrication; smooth, quiet power transmission
- Fast & easy installation; no special tools or accessories required

### HOW TO ORDER

#### FLANGE

EXAMPLE: **9SX1-9/16**

**9** **S** **X1-1/16**

**9**: 4FLEX FLANGE SIZE

**S**: 4FLEX FLANGE TYPE

**X1-1/16**: BORE SIZE (1 1/16")

EXAMPLE: **8B-SH**

**8** **B** **SH**

**8**: 4FLEX FLANGE SIZE

**B**: 4FLEX FLANGE TYPE

**SH**: QD HUB SIZE

#### ELEMENT MATERIAL

EXAMPLE: **9JES**

**9** **JES**

**9**: 4FLEX ELEMENT SIZE

**JES**: ELEMENT MATERIAL AND CONSTRUCTION (EPDM SPLIT - "S" STANDS FOR SPLIT)

**145** **NOTE:** INSTRUCTIONS ON HOW TO INSTALL INCLUDED WITH EACH FLANGE.

## General Characteristics:

- Sizes available 3-10
- Sizes in progress 11-13
- Torque (in./lbs.) 60 - 47,268
- Torsional wind-up 7° - 15°
- Parallel misalignment (in.) 0.010 - 0.040
- Sleeve Elements: 1-piece, 2-piece & split format  
EPDM & Hytrel

## Technical Features

- Tight bore tolerance (+.0005 / +.0015)
- Over 1000 HP @ 1750 rpm
- J & S flanges are bored to size
- B flanges are mounted with a QD bushing



### TYPES J & S 4-FLEX COUPLING FLANGES

- Available in different bore sizes to fit on standard shafts
- Most flanges have a keyseat and all are supplied with 2 setscrews



### TYPE B 4-FLEX COUPLING FLANGES

- Fits with our QD bushing for easy installation & removal
- Secure mounting without setscrews



## TYPE "J" COUPLING FLANGE

### IMPORTANT REMINDER



**NOTE: Not to be used with hytrel sleeves.**

### DIMENSIONS

Flange Size	List Price \$	Dimensions (inches)								*Wt. (lbs.)
		C	D	E	G	H	L	T	X	
3J	7.50	51/64	2.062	13/32	3/8	1 1/2	1 31/32	25/64	5/8	0.3
4J	9.50	55/64	2.460	27/64	5/8	1 5/8	2 11/32	7/16	5/8	0.4
5J	15.00	1 3/64	3.250	29/64	3/4	1 7/8	2 27/32	19/32	59/64	0.9
6J	21.00	1 5/16	4.000	9/16	7/8	2 1/2	3 1/2	3/4	1 3/32	1.2

\* Approximate weight for each flange

### STOCK BORES

Flange Size	Stock Bore (inches)	Keyseat
3J	3/8 - 1/2 5/8 - 3/4 - (7/8)	none 3/16 x 3/32
4J	1/2 5/8 - 3/4 - 7/8 15/16 - 1	none 3/16 x 3/32 1/4 x 1/8
5J	1/2 5/8 - 3/4 - 7/8 15/16 - 1 - 1 1/8	none 3/16 x 3/32 1/4 x 1/8
6J	5/8 - 3/4 - 7/8 15/16 - 1 - 1 1/8 - 1 3/16 - 1 1/4 1 3/8	3/16 x 3/32 1/4 x 1/8 5/16 x 5/32

( ) = Price and availability on request  
All finished bores come with 2 setscrews

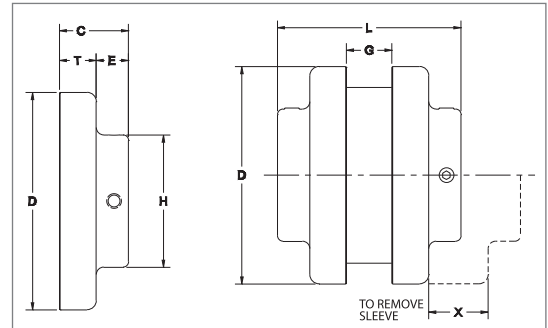

## TYPE "S" COUPLING FLANGE

Note: Can be used with both sleeve types.

### DIMENSIONS

Flange Size	List Price \$	Dimensions (inches)								*Wt. (lbs.)
		C	D	E	G	H	L	T	X	
5S	20.00	1 11/32	3.250	29/64	23/32	1 7/8	2 13/16	19/32	31/32	1.1
6S TYPE1	26.00	1 5/8	4.000	17/32	7/8	2 1/2	3 1/2	25/32	1 3/32	1.9
6S TYPE2	26.00	1 5/16	4.000	17/32	7/8	2 1/2	3 1/2	25/32	1 3/32	1.8
6S TYPE3	26.00	1 9/16	4.000	25/32	7/8	2 13/16	4	25/32	1 3/32	1.8
7S	30.00	1 27/32	4.625	11/16	1	2 13/16	3 15/16	25/32	1 5/16	2.6
8S TYPE1	40.00	2 3/32	5.450	3/4	1 1/8	3 1/4	4 7/16	29/32	1 1/2	4.4
8S TYPE2	40.00	1 15/16	5.450	1 1/32	1 1/8	3 1/4	5	29/32	1 1/2	3.7
9S TYPE1	60.00	2 13/32	6.350	25/32	1 7/16	3 7/8	5 1/16	1 1/32	1 3/4	6.8
9S TYPE2	60.00	2 9/32	6.350	1 1/4	1 7/16	4 1/8	6	1 1/32	1 3/4	6.2
10S TYPE1	80.00	2 23/32	7.500	13/16	1 5/8	4 3/8	5 11/16	1 7/32	2	10.5
10S TYPE2	80.00	2 11/16	7.500	1 15/32	1 5/8	4 3/4	7	1 7/32	2	9.8
(11S TYPE 1)	128.00	3 7/16	8.625	1 1/8	1 7/8	5 1/4	7 1/8	1 1/2	2 3/8	16.6
(11S TYPE 2)	128.00	3 1/16	8.625	1 9/16	1 7/8	5 5/8	8	1 1/2	2 3/8	16.4
(12S)	156.00	4	10.000	1 9/32	2 5/16	5 3/4	8 1/4	1 11/16	2 11/16	26.6
(*13S)	220.00	4 3/8	11.750	1 5/16	2 11/16	6 3/4	9 1/4	1 31/32	3 1/16	45.2

\* Approximate weight for each flange  
All finished bores come with 2 set screws.

( ) = Price and availability on request

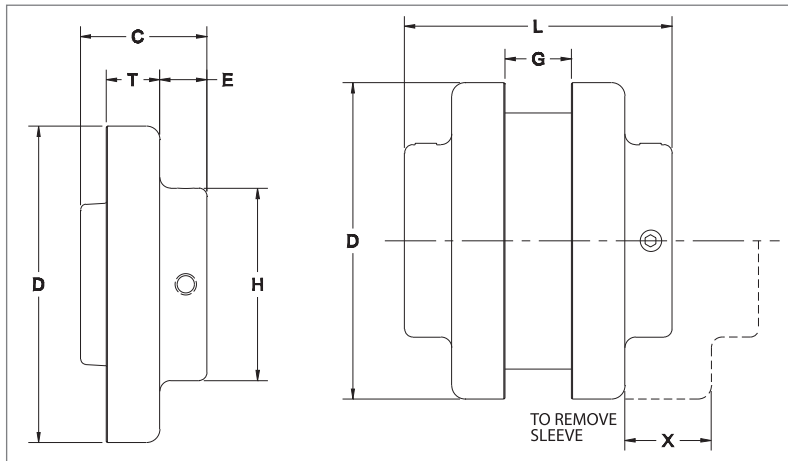

## TYPE "S" COUPLING FLANGE

The Maska 4-Flex are available from stock in all bores and keyseats listed below. In some cases, as the bore increases in diameter, a shallow keyseat is provided - due to insufficient material thickness. When this happens, Maska furnishes the correct rectangular key at no charge. This does not affect the coupling's ability to transmit the load. The rectangular key, or flat key as some call it, fits into the standard keyway in the shaft.

### STOCK BORES

Flange Size	Stock Bore (inches)	Keyseat
<b>5S</b>	1/2	none
	5/8 - 3/4 - 13/16 - 7/8	3/16 x 3/32
	15/16 - 1 - 1 1/16 - 1 1/8	1/4 x 1/8
	1 3/16	1/4 x 1/8
<b>6S Type 1</b>	1 1/4	1/4 x 1/16**
	5/8 - 3/4 - 7/8	3/16 x 3/32
	15/16 - 1 - 1 1/16 - 1 1/8	1/4 x 1/8
	1 3/16 - 1 1/4	1/4 x 1/8
	1 5/16 - 1 3/8	5/16 x 5/32
<b>6S Type 2</b>	1 7/16	3/8 x 3/16
	1 1/2	3/8 x 1/8**
<b>6S Type 3</b>	1 5/8	3/8 x 1/8**
	1 3/4	3/8 x 1/16**
<b>7S</b>	1 7/8	1/2 x 1/16**
	5/8 - 3/4 - 7/8	3/16 x 3/32
	15/16 - 1 - 1 1/16 - 1 1/8	1/4 x 1/8
	1 3/16 - 1 1/4	1/4 x 1/8
	1 5/16 - 1 3/8	5/16 x 5/32
	1 7/16 - 1 1/2 - 1 5/8	3/8 x 3/16
	1 7/8	1/2 x 1/8**
<b>8S Type 1</b>	3/4 - 7/8	3/16 x 3/32
	15/16 - 1 - 1 1/8 - 1 3/16	1/4 x 1/8
	1 1/4	1/4 x 1/8
	1 5/16 - 1 3/8	5/16 x 5/32
	1 7/16 - 1 1/2 - 1 9/16 - 1 5/8	3/8 x 3/16
	1 11/16 - 1 3/4	3/8 x 3/16
	1 7/8 - 1 15/16	1/2 x 1/4
<b>8S Type 2</b>	2 1/8	1/2 x 3/16**
	2 3/8	5/8 x 1/8**
<b>9S Type 1</b>	7/8	3/16 x 3/32
	1 - 1 1/8 - 1 1/4	1/4 x 1/8
	1 3/8	5/16 x 5/32
	1 7/16 - 1 1/2 - 1 9/16 - 1 5/8	3/8 x 3/16
	1 11/16 - 1 3/4	3/8 x 3/16
	1 7/8 - 1 15/16 - 2 - 2 1/8	1/2 x 1/4
	2 3/16 - 2 1/4	1/2 x 1/4
	2 3/8 - 2 1/2	5/8 x 5/16

Flange Size	Stock Bore (inches)	Keyseat
<b>9S Type 2</b>	2 7/8	3/4 x 1/8**
	1 1/8 - 1 1/4	1/4 x 1/8
<b>10S Type 1</b>	1 3/8	5/16 x 5/32
	1 7/16 - 1 1/2 - 1 9/16 - 1 5/8	3/8 x 3/16
	1 11/16 - 1 3/4	3/8 x 3/16
	1 7/8 - 1 15/16 - 2 - 2 1/8	1/2 x 1/4
	2 3/16 - 2 1/4	1/2 x 1/4
	2 3/8 - 2 7/16 - 2 1/2 - 2 5/8	5/8 x 5/16
	2 3/4	5/8 x 5/16
	2 7/8	3/4 x 1/4**
<b>*10S Type 2</b>	3 3/8	7/8 x 3/16**
	1 1/4	none
<b>*11S Type 1</b>	1 3/8	5/16 x 5/32
	1 1/2 - 1 5/8 - 1 3/4	3/8 x 3/16
	1 7/8 - 2 - 2 1/8 - 2 1/4	1/2 x 1/4
	2 3/8 - 2 3/4	5/8 x 5/16
	2 7/8	3/4 x 3/8
	3 3/8	7/8 x 7/16
<b>*11S Type 2</b>	3 7/16	7/8 x 3/16**
	3 7/8	1 x 1/4**
<b>*12S</b>	1 1/2	none
	1 5/8 - 1 3/4	3/8 x 3/16
	1 7/8 - 2 1/8	1/2 x 1/4
	2 3/8 - 2 3/4	5/8 x 5/16
	2 7/8	3/4 x 3/8
	3 3/8 - 3 7/16	7/8 x 7/16
<b>*13S</b>	3 7/8	1 x 1/2
	2	none
	2 1/8	1/2 x 1/4
	2 3/8	5/8 x 5/16
	2 7/8	3/4 x 3/8
3 3/8 - 3 7/16	7/8 x 7/16	
3 15/16	1 x 1/2	

\* = Price and availability on request

\*\* Shallow keyseat

All finished bores come with 2 set screws

## TYPE "B" COUPLING FLANGE

### IMPORTANT REMINDER



**NOTE:** Not to be used with hytrel sleeves.

### DIMENSIONS

Flange Size	List Price \$	Bush. Size	Dimensions (inches)									~Max. Bore (inches)	*Wt. (lbs.)	
			C1	C2	D	E	F	G	L	T	X		Flange	Bush.
6B	38.00	JA	1 17/64	1	4.000	33/64	2	7/8	3 13/32	3/4	1 3/32	1 1/4	1.4	0.4
7B	44.00	JA	1 19/64	1	4.625	33/64	2	1	3 19/32	25/32	1 5/16	1 1/4	1.9	0.4
8B	50.00	SH	1 31/32	1 1/4	5.450	5/8	2 11/16	1 1/8	4 3/16	29/32	1 1/2	1 5/8	2.9	0.9
9B	62.00	SD	2 5/16	1 13/16	6.350	11/16	3 3/16	1 7/16	4 7/8	1 1/32	1 3/4	1 15/16	4.8	1.6
10B	84.00	SK	2 1/32	1 7/8	7.500	13/16	3 7/8	1 5/8	5 11/16	1 7/32	2	2 1/2	7.8	2.7
(11B)	120.00	SF	2 5/16	2	8.625	13/16	4 5/8	1 7/8	6 1/2	1 1/2	2 3/8	2 15/16	12.0	3.9
(12B)	146.00	E	2 29/32	2 5/8	10.000	1 1/8	6	2 5/16	7 15/16	1 11/16	2 11/16	3 1/2	18.0	8.5
(13B)	208.00	F	3 29/32	3 5/8	11.750	1 7/32	6 5/8	2 11/16	9 1/16	1 31/32	3	3 15/16	31.2	13.3

~ Maximum bore with keyseat  
( ) = Price on request

\* Approximate weight for each flange

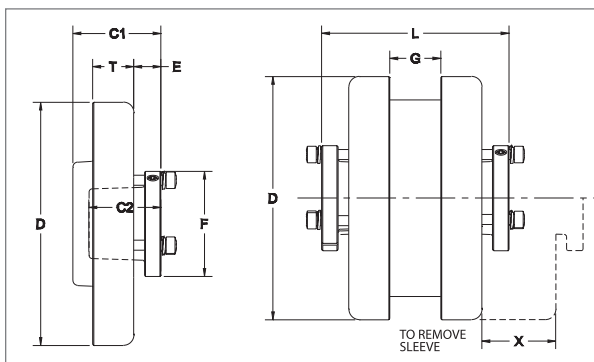



## ELEMENT CHARACTERISTICS

### SLEEVE TYPES

SHAPES AVAILABLE	EPDM	HYTREL
1 pc, unsplit	JE	H
1 pc, split	JES	-
2 pieces	E	HS
TYPICAL USE	General Purpose	General Purpose
REL. RATING	1X	4X
WIND-UP ANGULAR MISALIGNMENT	15°	7°
	1°	1/4°
TEMPERATURE		
maximum	+275° F.	+250° F.
minimum	-30° F.	-65° F.



JE



HS

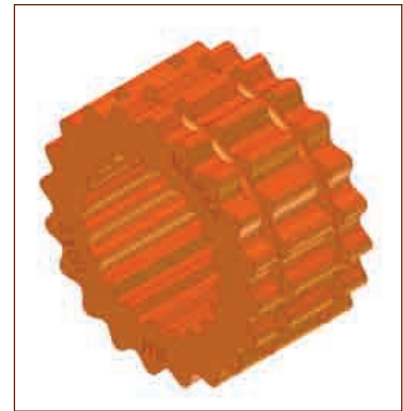

H



JES



E



E (exploded)

## EPDM ELEMENT - TYPES "JE", "JES", "E"

### DIMENSIONS

Part #	List Price \$	Part #	List Price \$	Coupling Size	D (inches)	W (inches)	Wt. (lbs)
3JE	4.20	3JES	5.60	3	1 7/8	1	0.06
4JE	6.00	4JES	8.00	4	2 5/16	1 1/4	0.10
5JE	12.00	5JES	14.00	5	2 15/16	1 9/16	0.20
6JE	20.00	6JES	22.00	6	3 3/4	1 7/8	0.40
7JE	26.00	7JES	28.00	7	4 11/32	2 3/16	0.62
8JE	34.00	8JES	38.00	8	5 1/16	2 1/2	1.13
9JE	40.00	9JES	44.00	9	6	3	1.46
10JE	56.00	10JES	60.00	10	7 1/16	3 7/16	2.32
(11E)	164.00	---		11	8 3/16	4	5.10
(12E)	240.00	---		12	9 9/16	4 11/16	8.10
(13E)	420.00	---		13	11 3/16	5 1/2	13.00

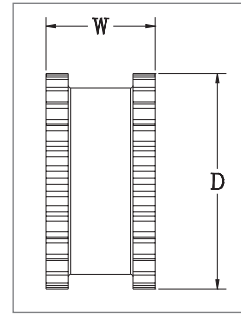

JE & JES

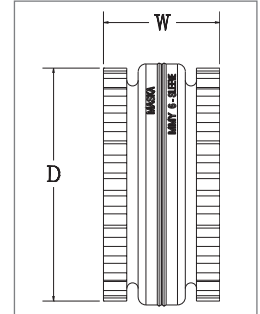

E

( ) = Price on request

### COUPLING RATINGS & MISALIGNMENT

Flange Size	EPDM Element	Max. RPM	HP PER 100 RPM					Torque (in. lbs.)	Stiffness (in. lbs./rad)	E (inches)	Allow. Misalignment (inches)	
			Service Factor								Parallel	Angular
			1.0	1.5	2.0	2.5	3.0					
3	JE, JES	9200	0.1	0.07	0.05	0.04	0.03	60	229	1.188	0.010	0.035
4	JE, JES	7600	0.2	0.13	0.10	0.08	0.07	120	458	1.500	0.010	0.043
5	JE, JES	7600	0.4	0.27	0.20	0.16	0.13	240	916	1.938	0.015	0.056
6	JE, JES	6000	0.7	0.47	0.35	0.28	0.23	450	1718	2.375	0.015	0.070
7	JE, JES	5250	1.2	0.80	0.60	0.48	0.40	725	2769	2.563	0.020	0.081
8	JE, JES	4500	1.8	1.20	0.90	0.72	0.60	1135	4335	2.938	0.020	0.094
9	JE, JES	3750	2.9	1.93	1.45	1.16	0.97	1800	6875	3.500	0.025	0.109
10	JE, JES	3600	4.6	3.07	2.30	1.84	1.53	2875	10980	4.063	0.025	0.128
(11)	E	3600	7.2	4.80	3.60	2.88	2.40	4530	17300	4.875	0.032	0.151
(12)	E	2800	11.4	7.60	5.70	4.56	3.80	7200	27500	5.688	0.032	0.175
(13)	E	2400	18.0	12.00	9.00	7.20	6.00	11350	43350	6.625	0.040	0.195

( ) = Price on request

COUPLINGS

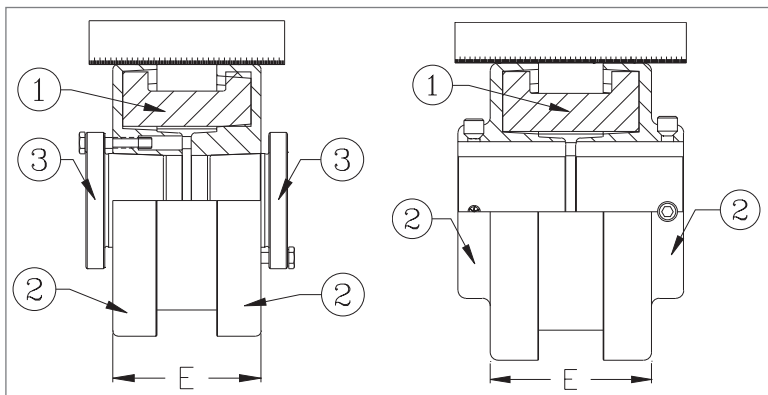

"B" FLANGES

"J", "S" FLANGES

1. SLEEVE
2. FLANGE
3. BUSHING

## HYTREL ELEMENT - TYPES "H", "HS"

### DIMENSIONS

Part #	List Price \$	Part #	List Price \$	Coupling Size	D (inches)	W (inches)	Wt. (lbs)
6H	80.00	6HS	84.00	6	3 3/4	1 7/8	0.44
7H	116.00	7HS	120.00	7	4 11/32	2 3/16	0.69
8H	126.00	8HS	130.00	8	5 1/16	2 1/2	1.40
9H	166.00	9HS	172.00	9	6	3	1.80
10H	224.00	10HS	230.00	10	7 1/16	3 7/16	2.90
(11H)	346.00	(11HS)	354.00	11	8 3/16	4	4.50
(12H)	496.00	(12HS)	506.00	12	9 9/16	4 11/16	7.30
-	-	(13HS)	840.00	13	11 3/16	5 1/2	11.80

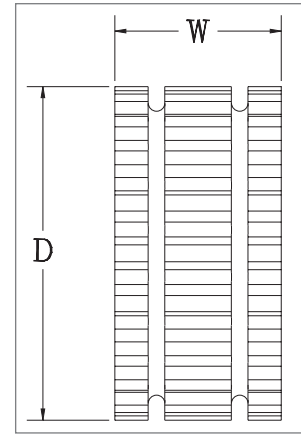

( ) = Price on request

### COUPLING RATINGS & MISALIGNMENT

Flange Size	Hytrel Sleeves	Max. RPM	HP PER 100 RPM					Torque (in. lbs.)	Stiffness (in. lbs./rad)	E (inches)	Allow. Misalignment (inches)	
			Service Factor								Parallel	Angul.
			1.0	1.5	2.0	2.5	3.0					
6	H, HS	6000	2.90	1.93	1.45	1.16	0.97	1800	10000	2.375	0.010	0.016
7	H, HS	5250	4.60	3.07	2.30	1.84	1.53	2875	20000	2.563	0.012	0.020
8	H, HS	4500	7.20	4.80	3.60	2.88	2.40	4530	30000	2.938	0.015	0.025
9	H, HS	3750	11.4	7.60	5.70	4.56	3.80	7200	47500	3.500	0.017	0.028
10	H, HS	3600	18.0	12.00	9.00	7.20	6.00	11350	100000	4.063	0.020	0.032
(11)	H, HS	3600	28.6	19.07	14.30	11.44	9.53	18000	125000	4.875	0.022	0.037
(12)	H, HS	2800	50.0	33.33	25.00	20.00	16.67	31500	225000	5.688	0.025	0.042
(13)	HS	2400	75.0	50.00	37.50	30.00	25.00	47268	368900	6.625	0.030	0.050

( ) = Price on request

COUPLINGS

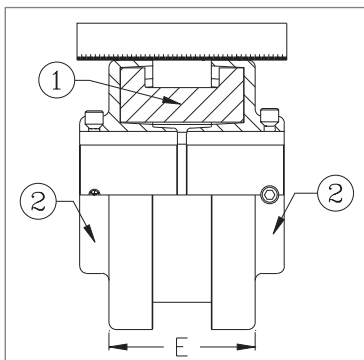

1. SLEEVE
2. FLANGE
3. BUSHING

"S" FLANGES

## COUPLING SELECTION - SERVICE FACTORS FOR ELEMENT MATERIALS EPDM - "JE", "JES", "E"

860 RPM MOTORS						1160 RPM MOTORS						1750 RPM MOTORS						3500 RPM MOTORS					
HP	Service Factors					HP	Service Factors					HP	Service Factors					HP	Service Factors				
	1.0	1.25	1.5	2.0	2.5		1.0	1.25	1.5	2.0	2.5		1.0	1.25	1.5	2.0	2.5		1.0	1.25	1.5	2.0	2.5
1/2	3	3	3	4	4	1/2	3	3	3	3	4	1/2	3	3	3	3	3	1/2	-	-	-	-	-
3/4	3	4	4	4	5	3/4	3	3	4	4	4	3/4	3	3	3	3	4	3/4	3	3	3	3	3
1	4	4	4	5	5	1	3	4	4	4	5	1	3	3	3	4	4	1	3	3	3	3	3
1 1/2	4	5	5	5	6	1 1/2	4	4	5	5	5	1 1/2	3	4	4	4	5	1 1/2	3	3	3	3	4
2	5	5	5	6	6	2	4	5	5	5	6	2	4	4	4	5	5	2	3	3	3	4	4
3	5	6	6	6	7	3	5	5	6	6	6	3	4	5	5	5	6	3	3	4	4	4	5
5	6	6	7	7	8	5	6	6	6	7	7	5	5	5	6	6	6	5	4	4	5	5	5
7 1/2	7	7	8	8	9	7 1/2	6	7	7	8	8	7 1/2	6	6	6	7	7	7 1/2	5	5	5	6	6
10	7	8	8	9	9	10	7	7	8	8	9	10	6	6	7	7	8	10	5	5	6	6	6
15	8	9	9	10	10	15	8	8	9	9	10	15	7	7	8	8	9	15	6	6	6	7	7
20	9	9	10	10	11	20	8	9	9	10	10	20	7	8	8	9	9	20	6	6	7	7	8
25	9	10	10	11	11	25	9	9	10	10	11	25	8	8	9	9	10	25	6	7	7	8	8
30	10	10	11	11	12	30	9	10	10	11	11	30	8	9	9	10	10	30	7	7	8	8	9
40	10	11	11	12	12	40	10	10	11	11	12	40	9	9	10	10	11	40	7	8	8	9	9
50	11	11	12	12	13	50	10	11	11	12	12	50	9	10	10	11	11	50	8	8	9	9	10
60	11	12	12	13	13	60	11	11	12	12	13	60	10	10	11	11	12	60	8	9	9	10	10
75	12	12	13	13	-	75	11	12	12	13	13	75	10	11	11	12	12	75	9	9	10	10	11
100	12	13	13	-	-	100	12	12	13	13	-	100	11	11	12	12	13	100	9	10	10	11	11
125	13	13	-	-	-	125	12	13	13	-	-	125	11	12	12	13	13	125	10	10	11	11	-
150	13	-	-	-	-	150	13	13	-	-	-	150	12	12	13	13	-	150	10	11	11	-	-
200	-	-	-	-	-	200	13	-	-	-	-	200	12	13	13	-	-	200	11	11	-	-	-
250	-	-	-	-	-	250	-	-	-	-	-	250	13	13	-	-	-	250	11	-	-	-	-
300	-	-	-	-	-	300	-	-	-	-	-	300	13	-	-	-	-	300	-	-	-	-	-

COUPLINGS



## COUPLING SELECTION - SERVICE FACTORS FOR ELEMENT MATERIALS HYTREL - "H", "HS"

860 RPM MOTORS						1160 RPM MOTORS					1750 RPM MOTORS					3500 RPM MOTORS							
HP	Service Factors					HP	Service Factors					HP	Service Factors					HP	Service Factors				
	1.0	1.25	1.5	2.0	2.5		1.0	1.25	1.5	2.0	2.5		1.0	1.25	1.5	2.0	2.5		1.0	1.25	1.5	2.0	2.5
7 1/2	6	6	6	6	6	7 1/2	-	-	-	-	-	7 1/2	-	-	-	-	-	7 1/2	-	-	-	-	-
10	6	6	6	6	6	10	6	6	6	6	6	10	-	-	-	-	-	10	-	-	-	-	-
15	6	6	6	7	7	15	6	6	6	6	7	15	6	6	6	6	6	15	-	-	-	-	-
20	6	6	7	7	8	20	6	6	6	7	7	20	6	6	6	6	6	20	-	-	-	-	-
25	6	7	7	8	8	25	6	6	7	7	8	25	6	6	6	6	7	25	-	-	-	-	-
30	7	7	8	8	9	30	6	7	7	8	8	30	6	6	6	7	7	30	6	6	6	6	6
40	7	8	8	9	9	40	7	7	8	8	9	40	6	6	7	7	8	40	6	6	6	6	6
50	8	8	9	9	10	50	7	8	8	9	9	50	6	7	7	8	8	50	6	6	6	6	7
60	8	9	9	10	10	60	8	8	9	9	10	60	7	7	8	8	9	60	6	6	6	7	7
75	9	9	10	10	11	75	8	9	9	10	10	75	7	8	8	9	9	75	6	6	7	7	8
100	9	10	10	11	11	100	9	9	10	10	11	100	8	8	9	9	10	100	6	7	7	8	8
125	10	10	11	11	12	125	9	10	10	11	11	125	8	9	9	10	10	125	7	7	8	8	9
150	10	11	11	12	12	150	10	10	11	11	12	150	9	9	10	10	11	150	7	8	8	9	9
200	11	11	12	12	13	200	10	11	11	12	12	200	9	10	10	11	11	200	8	8	9	9	10
250	11	12	12	13	13	250	11	11	12	12	13	250	10	10	11	11	12	250	8	9	9	10	10
300	12	12	13	13	-	300	11	12	12	13	13	300	10	11	11	12	12	300	9	9	10	10	11
350	12	12	13	-	-	350	12	12	12	13	-	350	11	11	12	12	12	350	9	10	10	11	11
400	12	13	13	-	-	400	12	12	13	13	-	400	11	11	12	12	13	400	9	10	10	11	11
500	13	13	-	-	-	500	12	13	13	-	-	500	11	12	12	13	13	500	10	10	11	11	-
600	13	-	-	-	-	600	13	13	13	-	-	600	12	12	13	13	-	600	10	11	11	-	-
700	-	-	-	-	-	700	13	13	-	-	-	700	12	12	13	-	-	700	11	11	-	-	-
800	-	-	-	-	-	800	13	-	-	-	-	800	12	13	13	-	-	800	11	11	-	-	-
900	-	-	-	-	-	900	-	-	-	-	-	900	13	13	-	-	-	900	11	-	-	-	-
1000	-	-	-	-	-	1000	-	-	-	-	-	1000	13	13	-	-	-	1000	11	-	-	-	-

COUPLINGS



155